

# Body-Solid

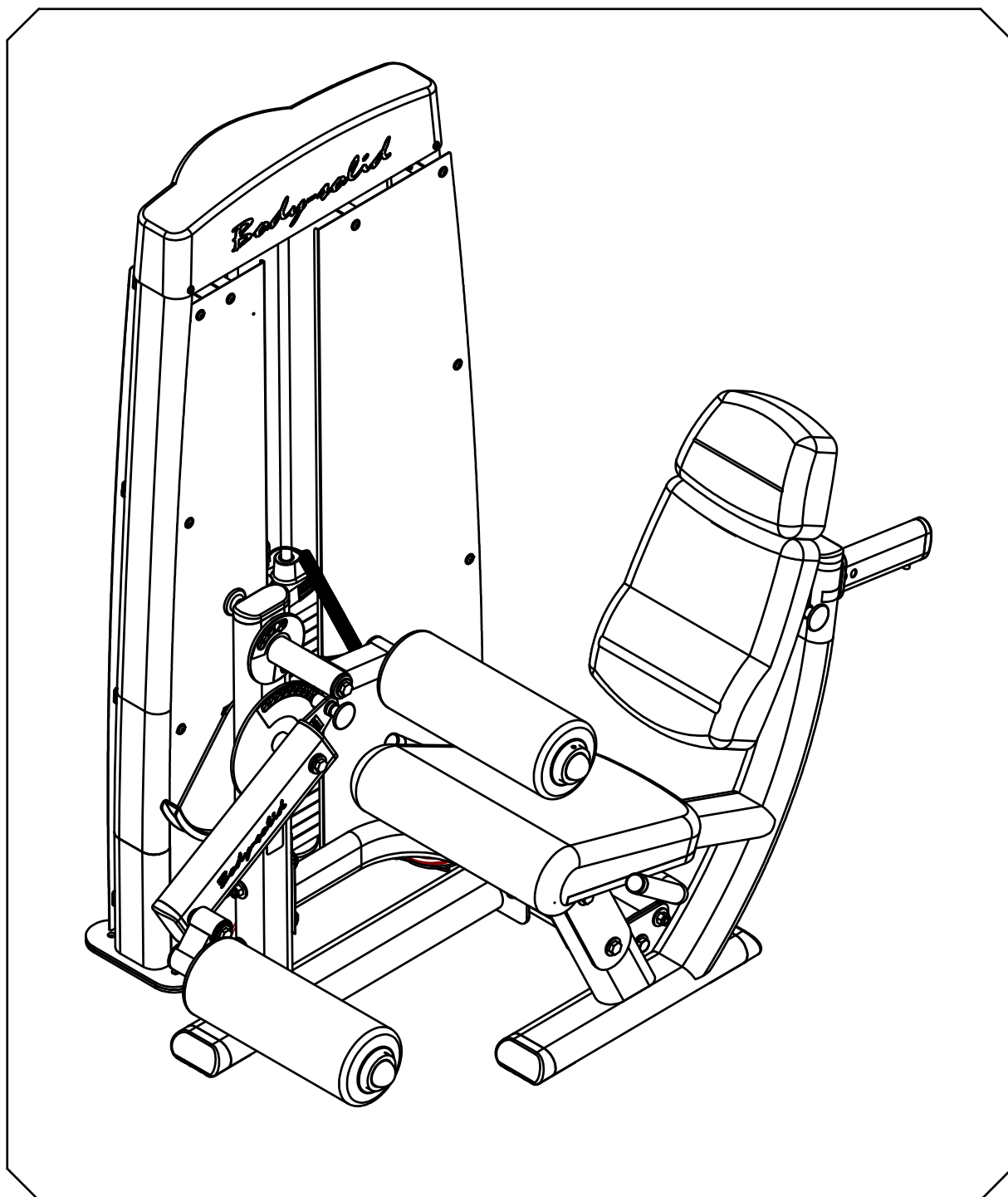

BODY-SOLID, Inc.  
1900 S. Des Plaines Ave.  
Forest Park, IL 60130 USA  
Phone: (708) 427-3555  
Fax: (708) 427-3556  
[www.bodysolid.com](http://www.bodysolid.com)

DLEC.2 OWNER'S MANUAL

# DLEC ASSEMBLY INSTRUCTIONS

## HARDWARW ILLUSTRATION

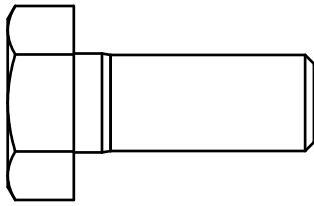

(A1)HEX BOLT 1/2"X1-1/4"L PARTIAL QTY.2

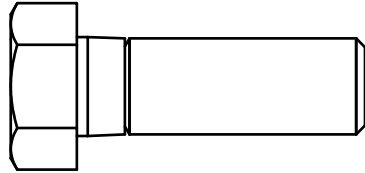

(A2)HEX BOLT 1/2"X1-1/2"L PARTIAL QTY.3

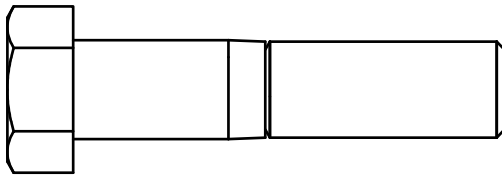

(A3)HEX BOLT 1/2"X2-1/4"L PARTIAL QTY.1

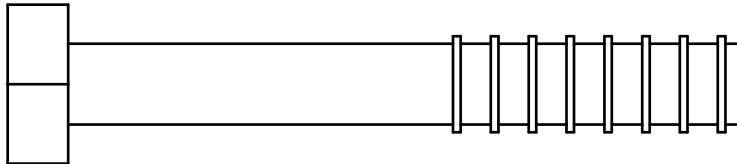

(A4)HEX BOLT 1/2"X3-1/2"L PARTIAL QTY.2

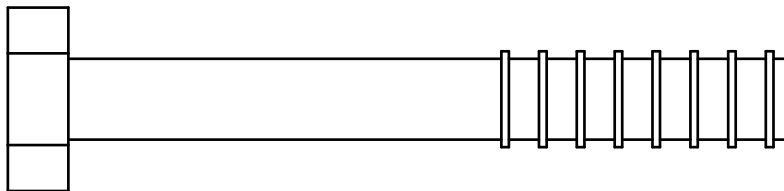

(A5)HEX BOLT 1/2"X3-3/4"L PARTIAL QTY.1

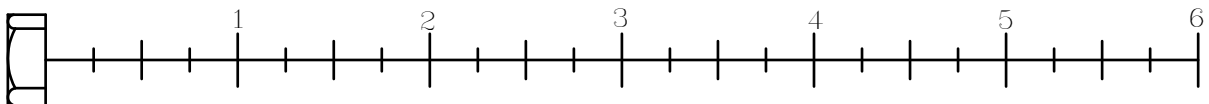

# DLEC ASSEMBLY INSTRUCTIONS

## HARDWARW ILLUSTRATION

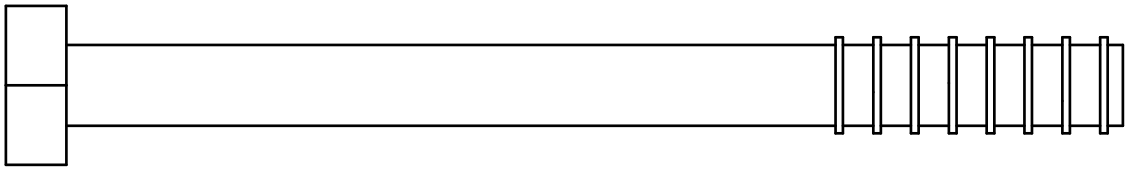

(A6)HEX BOLT 1/2"X5-1/2"L PARTIAL QTY.2

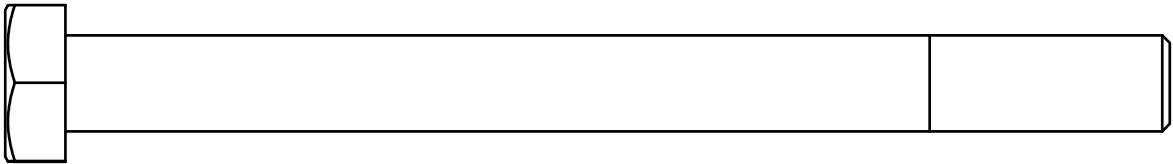

(A7)HEX BOLT 1/2"X5-3/4"L PARTIAL QTY.2

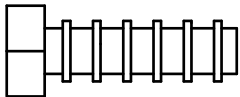

(A8)HEX BOLT 5/16"X1"L PARTIAL QTY.6

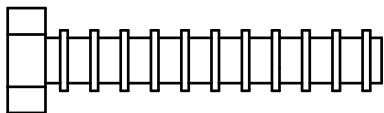

(A9)HEX BOLT 5/16"X1-3/4"L PARTIAL QTY.1

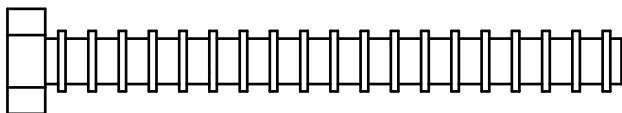

(A10)HEX BOLT 5/16"X3"L PARTIAL QTY.1

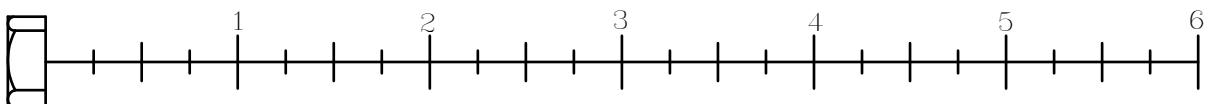

# DLEC ASSEMBLY INSTRUCTIONS

## HARDWARW ILLUSTRATION

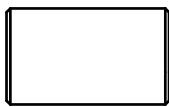
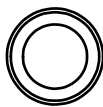

(A11)STEEL BUSHING  $\phi 1/2"$ X $\phi 8.5$ X21L QTY.1

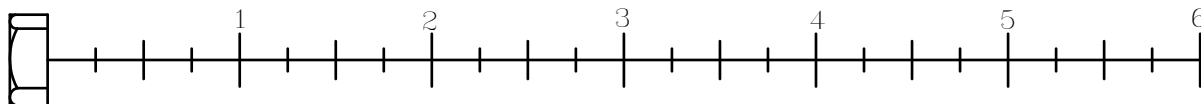

# DLEC ASSEMBLY INSTRUCTIONS

## HARDWARW ILLUSTRATION

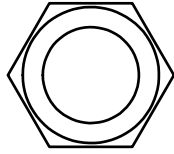
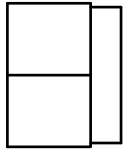

(B1) NYLON LOCK NUT 1/2" QTY.13

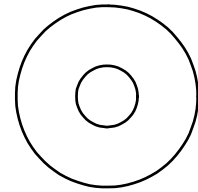

(C4) 5/16" (I.D.) FLAT WASHER Ø24 QTY.7

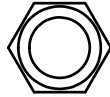

(B2) NYLON LOCK NUT 5/16" QTY.1

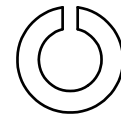

(C5) SPRING WASHER 5/16" QTY.7

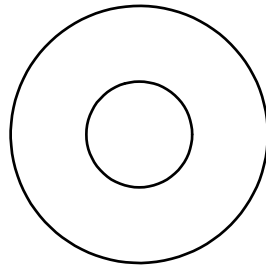

(C1) 1/2" (I.D.) FLAT WASHER Ø34 QTY.20

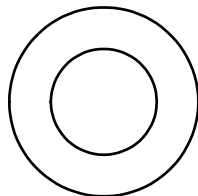

(C2) 1/2" (I.D.) FLAT WASHER Ø25 QTY.6

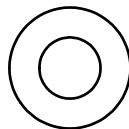

(C3) 5/16" (I.D.) FLAT WASHER Ø16 QTY.2

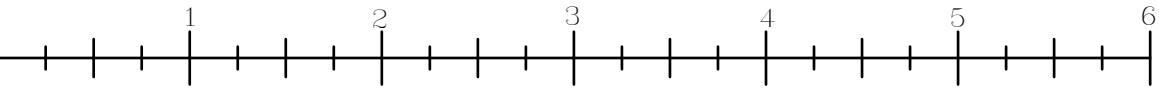

# DLEC ASSEMBLY INSTRUCTIONS

## HARDWARW ILLUSTRATION

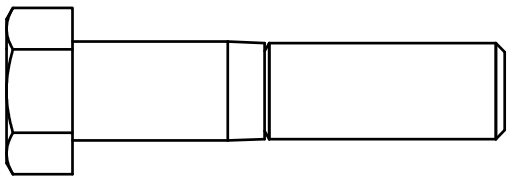

(AA2)HEX BOLT 1/2"X2-1/4"L PARTIAL QTY.3

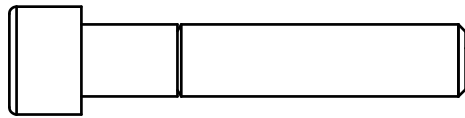
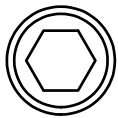

(AA4)ROUND INNER HEAD 3/8"X2"L PARTIAL QTY.1

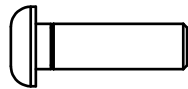

(AA5)ROUND INNER HEX SCREW M6X20L PARTIAL QTY.20



(AA6)ROUND CROSS SCREW 5/32"X1/4"L PARTIAL QTY.4

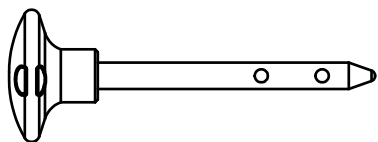

(AA7)10LB PIN(8250-071) QTY.1

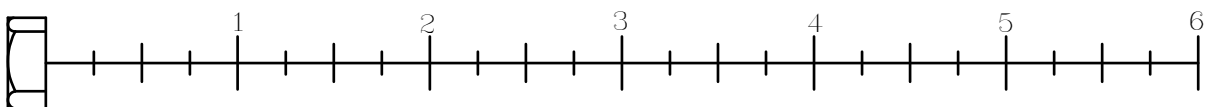

# DLEC ASSEMBLY INSTRUCTIONS

## HARDWARW ILLUSTRATION

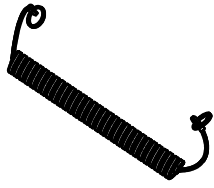

(AA8)ELASTIC BOLT QTY.1

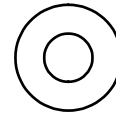

(CC2)M6(I.D.)FLAT WASHER Ø13 QTY.20

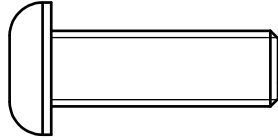
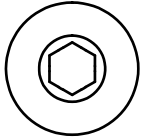

(AA10)ROUND INNER HEX SCREW  
M10X30L PARTIAL QTY.1

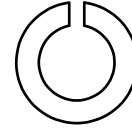
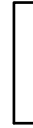

(CC5)SPRING WASHER 3/8" QTY.1

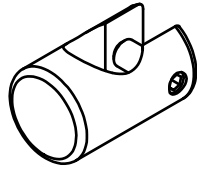

(AA11)FIRM SHEATH(8890-046) QTY.1

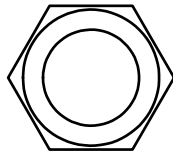
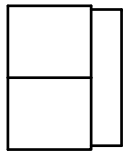
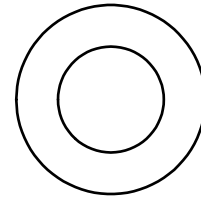
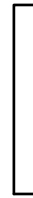

(CC6)1/2"(I.D.)FLAT WASHER Ø25 QTY.2

(BB2)NYLON LOCK NUT1/2" QTY.3

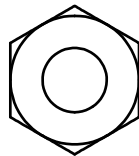
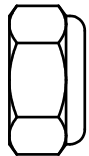

(BB3)NYLON LOCK NUT M10 QTY.1

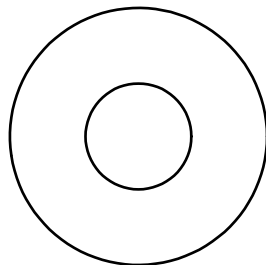













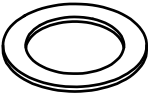

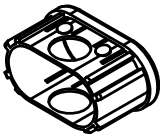
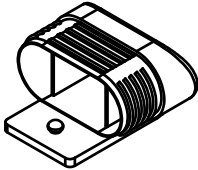

(CC1)1/2"(I.D.)FLAT WASHER Ø34 QTY.4

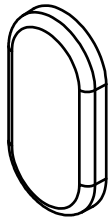

# DLEC ASSEMBLY INSTRUCTIONS

## HARDWARW ILLUSTRATION

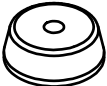
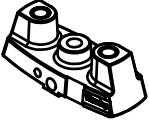
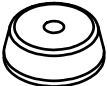
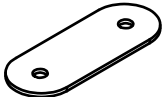
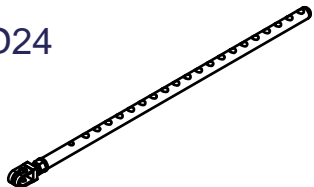
- |   |   |  |
|---|---|--|
| D1  | D2  | (D1) $\phi 3/4$ " X 13.5 X 8L STEEL BUSHING (8110-014) ----- [2PCS]        |
|      |      | (D2) $\phi 25.4$ X $\phi 20.4$ X 10L STEEL BUSHING (8120-040) ----- [1PCS] |
| D3  | D4  | (D3) $\phi 38$ " X $\phi 25.2$ X 27L STEEL BUSHING (8130-159) ----- [1PCS] |
|      |      | (D4) $\phi 30$ " X $\phi 20$ X 1.5t CU WASHER (8520-007) ----- [1PCS]      |
| D5  | D6  | (D5) $\phi 38$ " X $\phi 26$ X 1.5t CU WASHER (8520-008) ----- [3PCS]      |
|      |      | (D6) $\phi 50$ ROUND END CAP (9211-074) ----- [2PCS]                       |
| D7  | D8  | (D7) 50 X 100 NYLON BUSHING (9211-107) ----- [2PCS]                        |
|    |    | (D8) 58 X 116 X 2.5t X 65H FOOT CAP (9211-109) ----- [3PCS]                |
| D9  | D10   | (D9) 58 X 116 X 2.5t END CAP (9211-112) ----- [4PCS]                       |
|    |  | (D10) 40 X 80 X 2t END CAP (9211-113) ----- [1PCS]                         |
| D11   | D12   | (D11) $\phi 4$ " PULLEY (9213-017A) ----- [2PCS]                           |
|  |    | (D12) $\phi 4$ " 1/2" PULLEY (9213-010B) ----- [5PCS]                      |
| D13   | D14   | (D13) $\phi 50$ END CAP (9211-020) ----- [2PCS]                            |
|    |    | (D14) $\phi 90$ X $\phi 51$ X 3t NYLON WASHER (9214-022) ----- [4PCS]      |
| D15   | D16   | (D15) 207 X 105 X 23 END CAP (9211-115) ----- [1PCS]                       |
|  |  | (D16) $\phi 131$ X 30 END CAP (9211-116) ----- [1PCS]                      |
| D17   | D18   | (D17) 3580mm STEEL CABLE (FDLECA) ----- [1PCS]                             |
|    |    | (D18) $\phi 3/4$ " SHAFT COLLAR (9211-046) ----- [2PCS]                    |
| D19   | D20   | (D19) $\phi 4$ " RUBBER DOUNT (9310-017) ----- [2PCS]                      |
|    |  | (D20) TOP PLATE (8400-006) ----- [1PCS]                                    |
| D21   | D22   | (D21) $\phi 4$ " RUBBER DOUNT (9310-017) ----- [2PCS]                      |
|    |  | (D22) 95 X 250 RUBBER PAD (9310-060) ----- [2PCS]                          |
| D23   | D24   | (D23) DLEC FOR DGYM CABLE (FDLECB) ----- [1PCS]                            |
|    |   | (D24) WEIGHT SELECTOR BAR (8210-042B) ----- [1PCS]                         |



# DLEC ASSEMBLY INSTRUCTIONS

## PARTS ILLUSTRATION

A2 [1PCS]

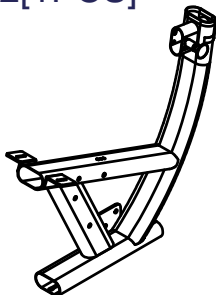

B [1PCS]

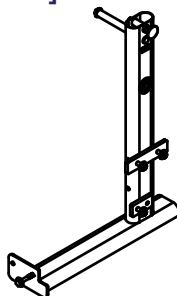

C [1PCS]

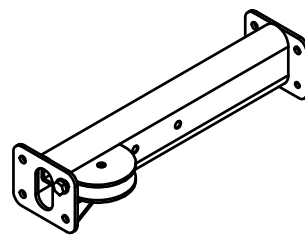

D [1PCS]

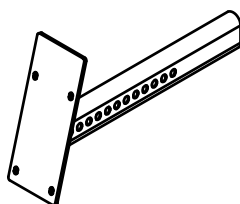

E [1PCS]

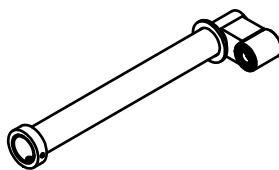

F [1PCS]

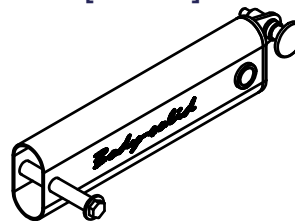

G1 [1PCS]

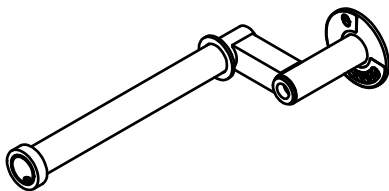

H [1PCS]



I [1PCS]

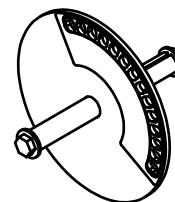

J [1PCS]

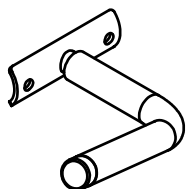

K [1PCS]

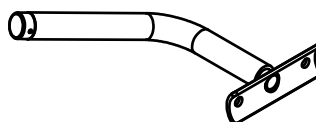

L [1PCS]

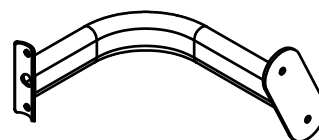

M [1PCS]  
8321-062

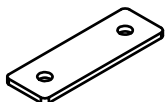

N [1PCS]  
8313-135

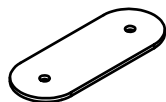

O [1PCS]  
9111-055

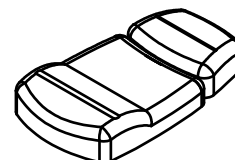

P [2PCS]  
9121-053

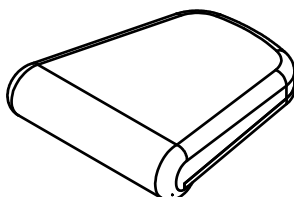

Q [2PCS]  
9161-034

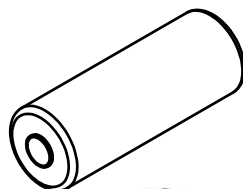

R [1PCS]  
9440-161

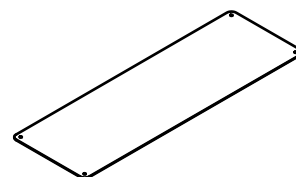

# DLEC ASSEMBLY INSTRUCTIONS

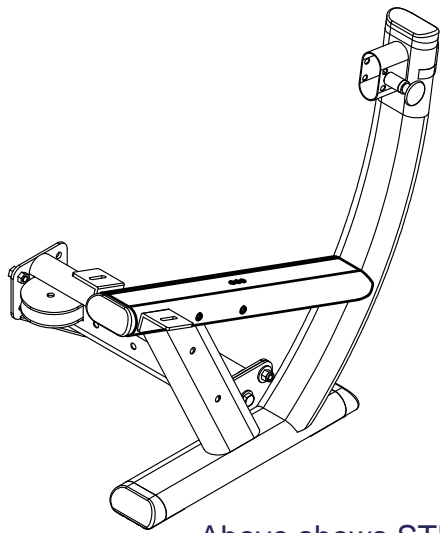

Above shows STEP 1  
assembled and completed

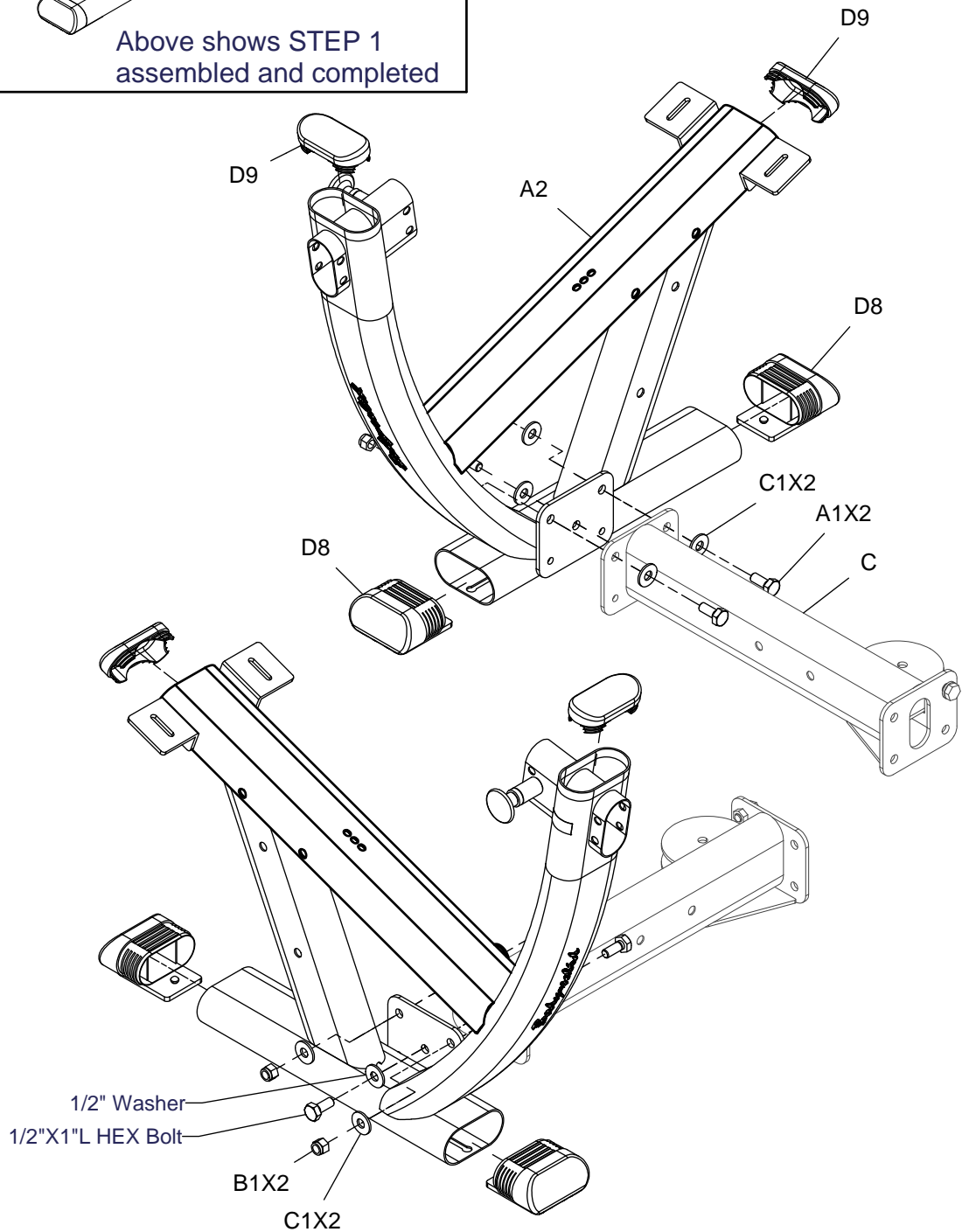

# DLEC ASSEMBLY INSTRUCTIONS

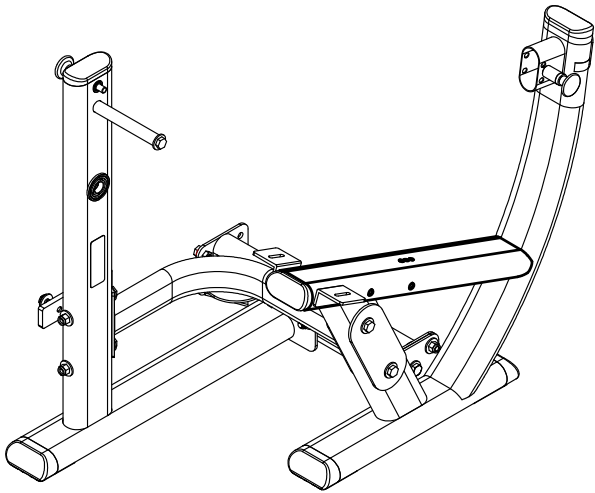

Above shows STEP 2 assembled and completed

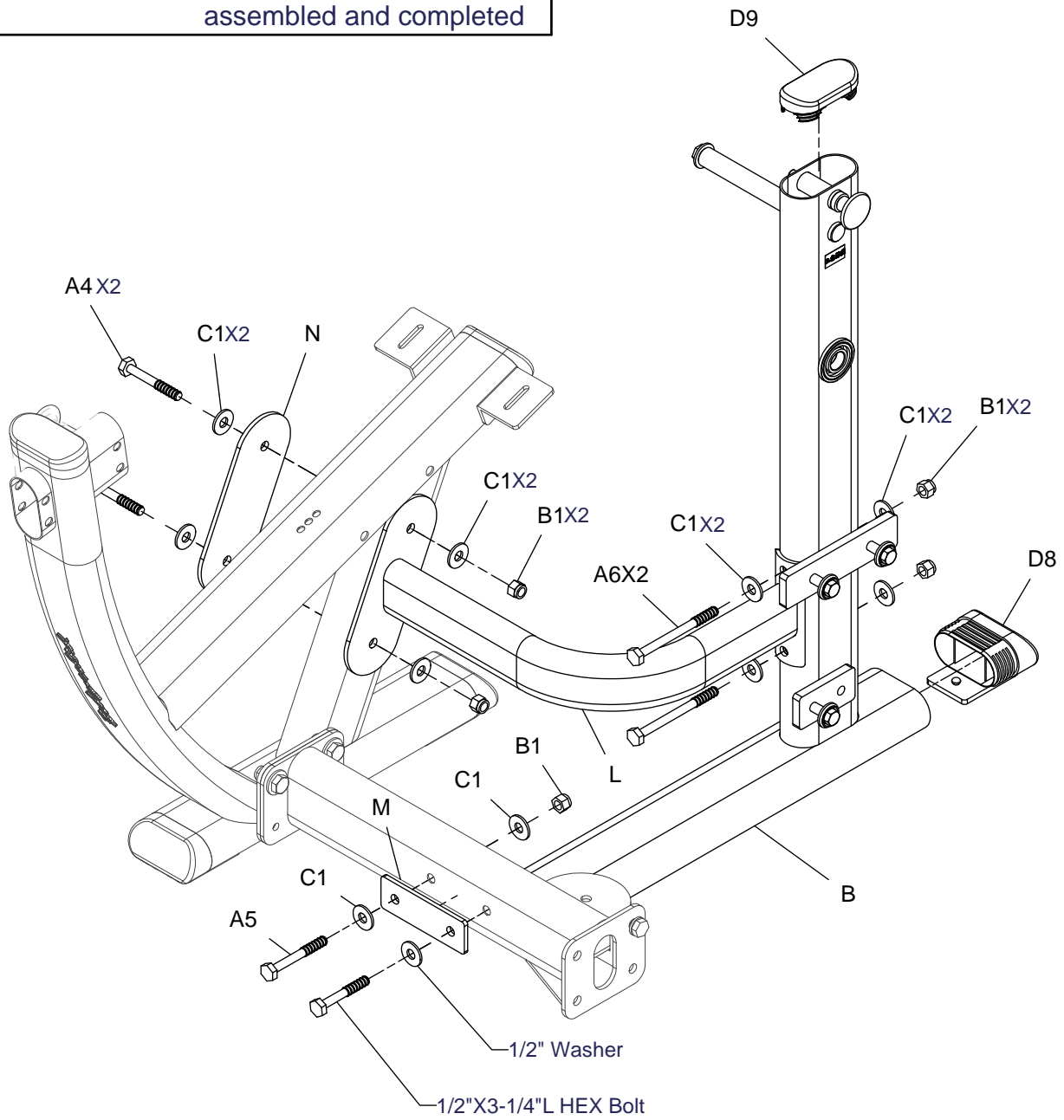

# DLEC ASSEMBLY INSTRUCTIONS

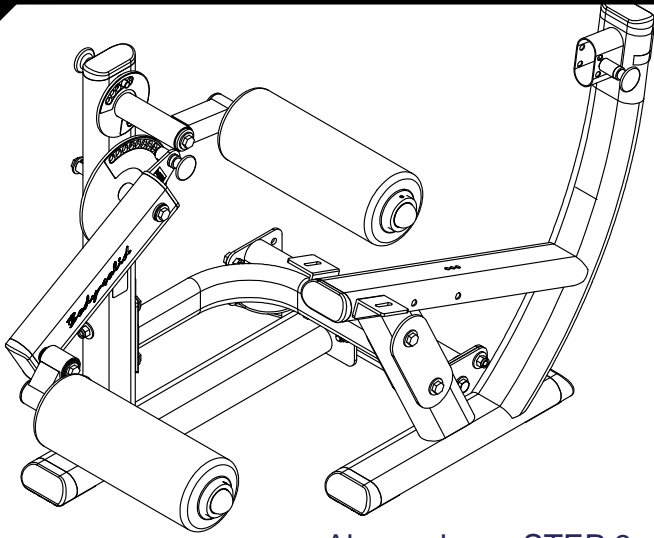

Above shows STEP 3 assembled and completed

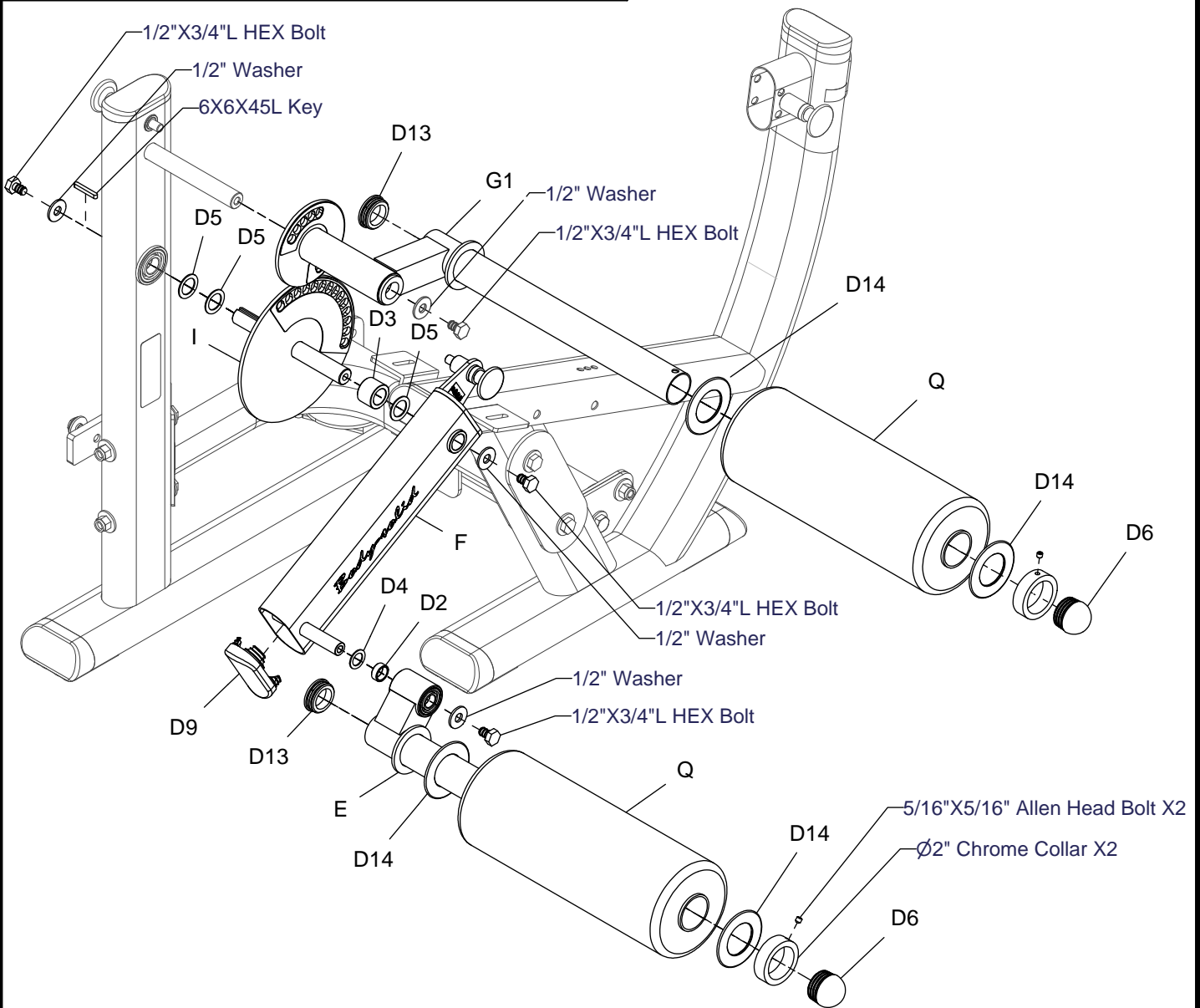

# DLEC ASSEMBLY INSTRUCTIONS

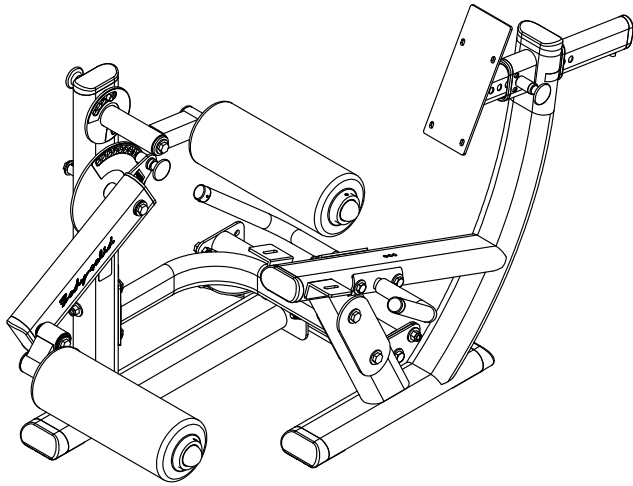

Above shows STEP 4  
assembled and completed

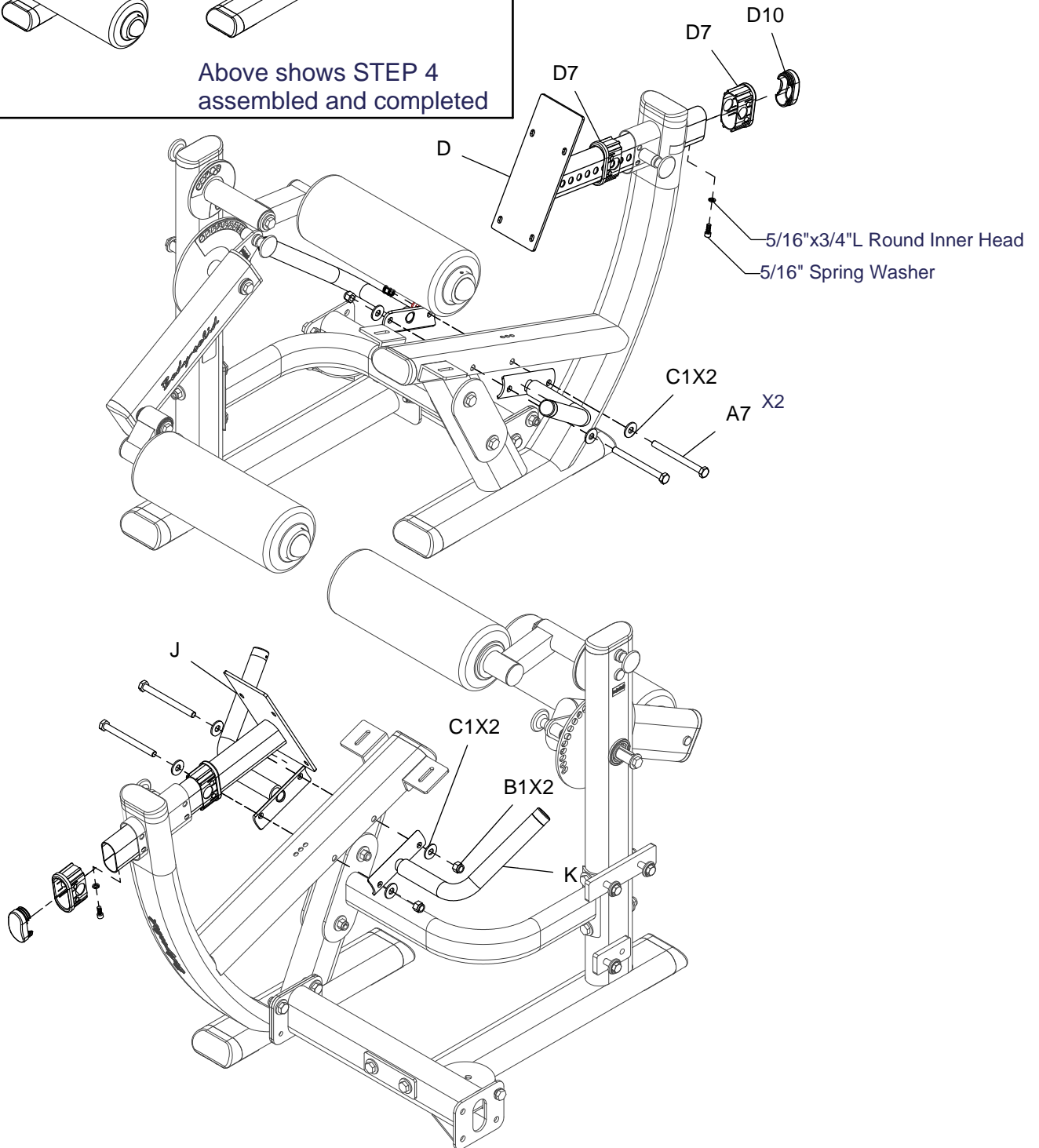

# DLEC ASSEMBLY INSTRUCTIONS

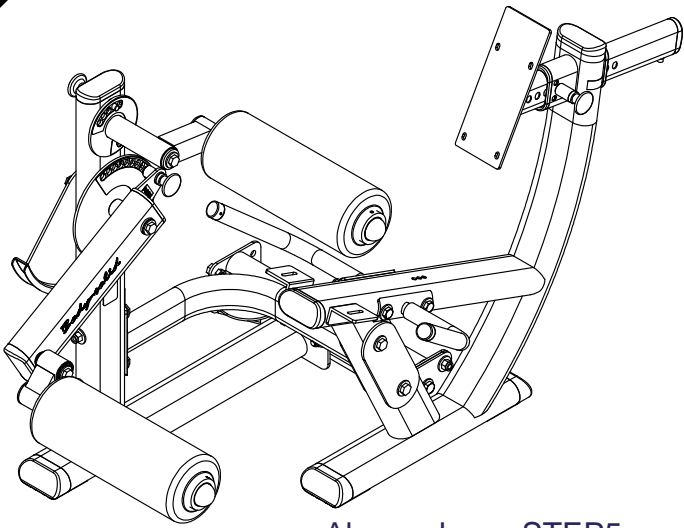

Above shows STEP5 assembled and completed

Detail View

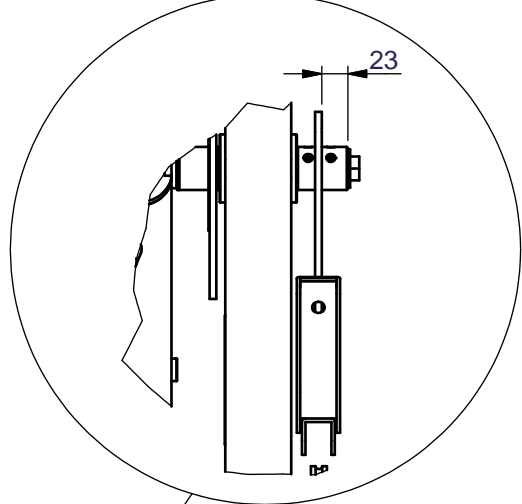

5/16"X5/16"L Allen Head Bolt X4

1/2" Washer X2

1/2"X3/4"L HEX Bolt X2

D11

D12

1/2"X1-1/2"L HEX Bolt X2

1/2" Washer X2

1/2" Round End Cap Washer X2

# DLEC ASSEMBLY INSTRUCTIONS

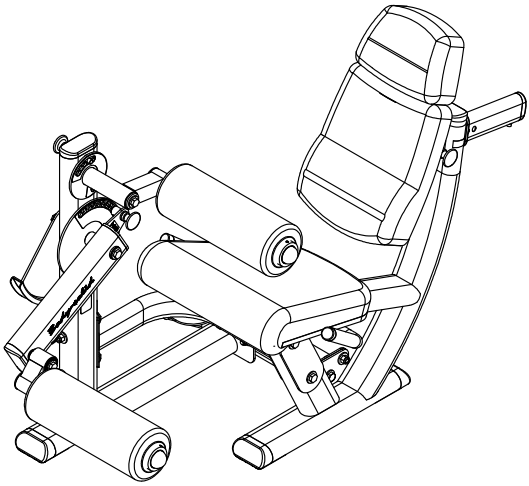

Above shows STEP 6 assembled and completed

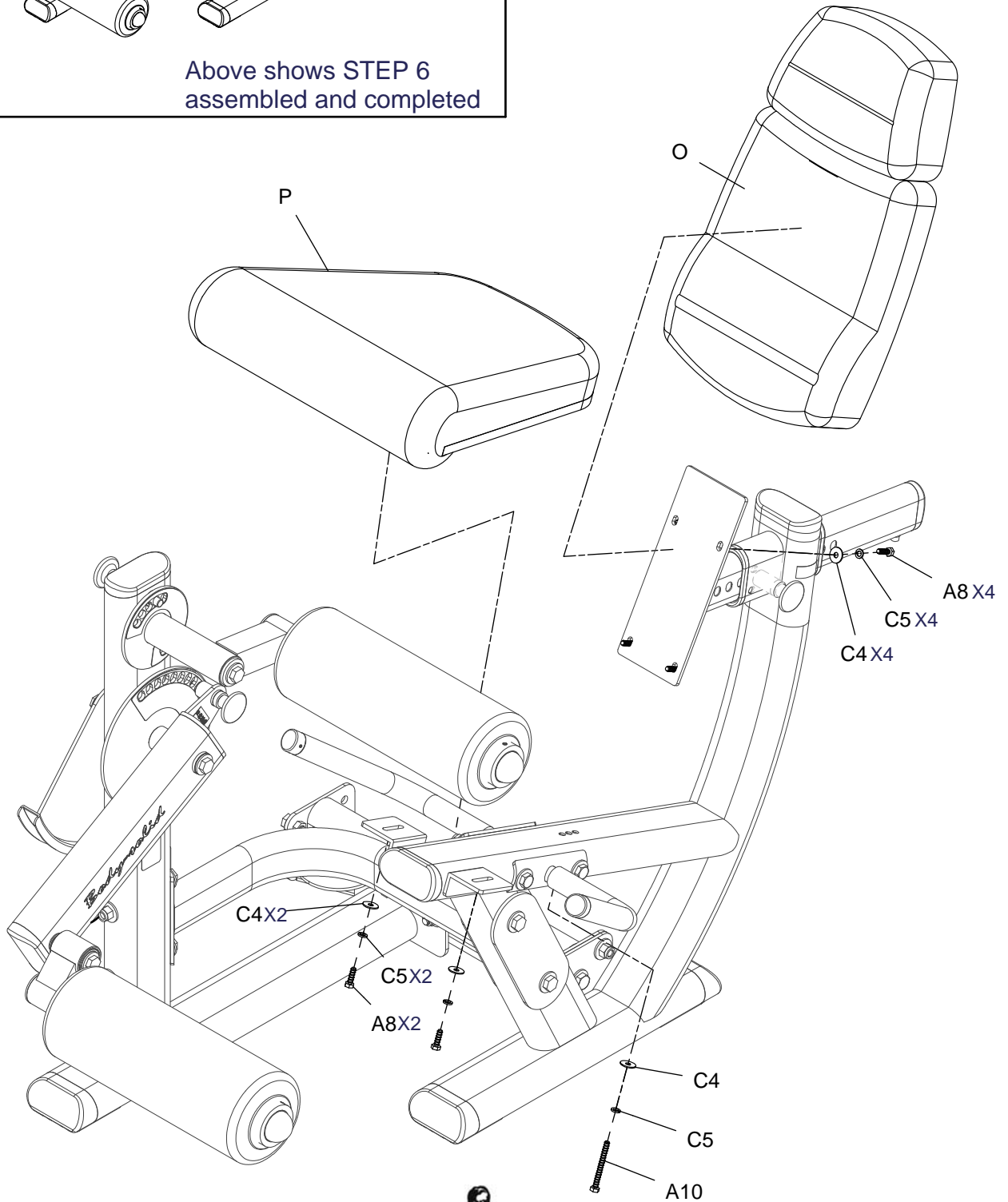



# DLEC ASSEMBLY INSTRUCTIONS

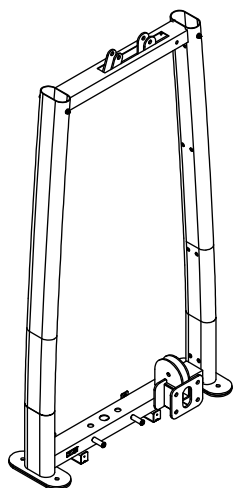

Above shows STEP 7  
assembled and completed

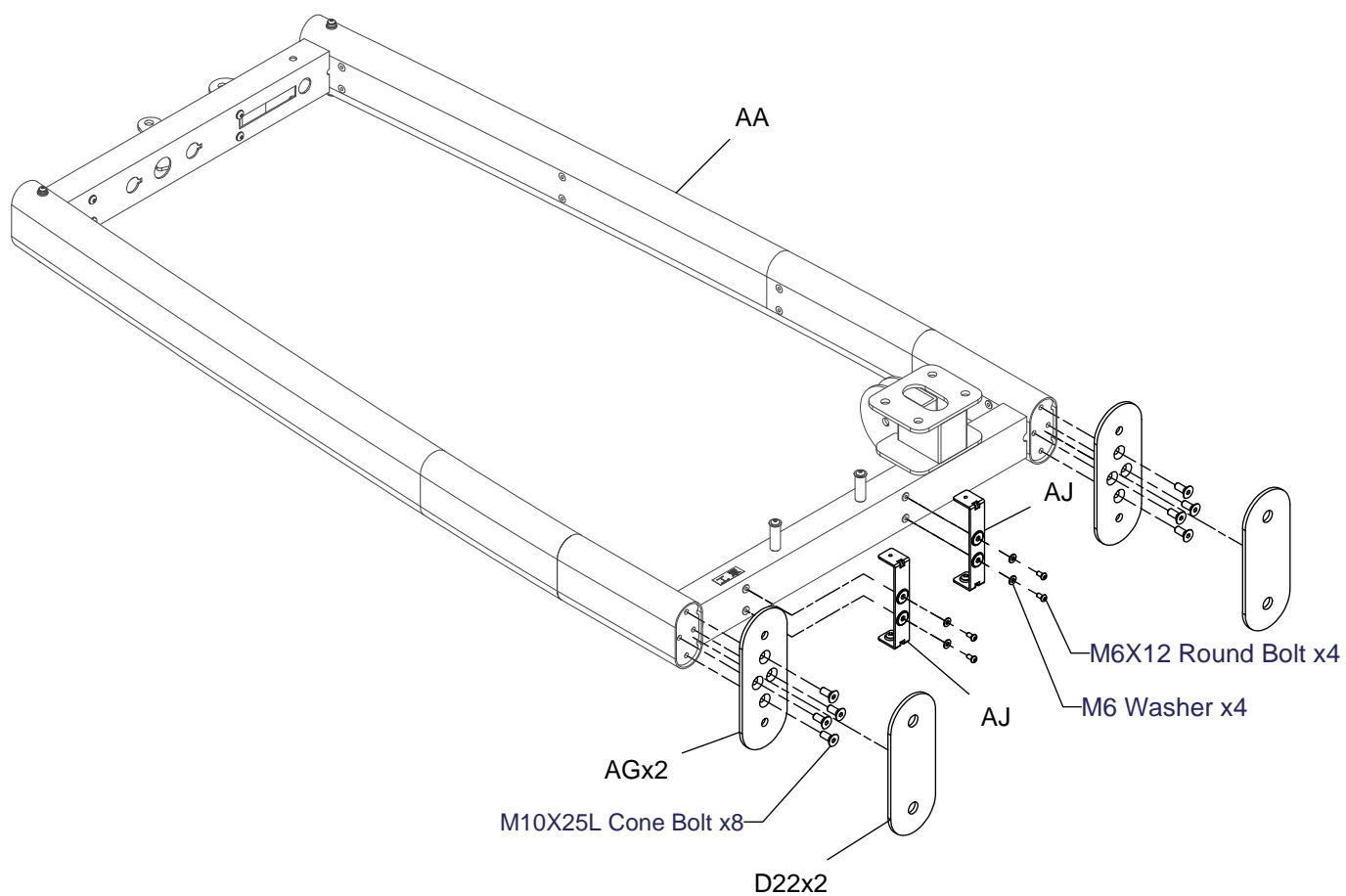



# DLEC ASSEMBLY INSTRUCTIONS

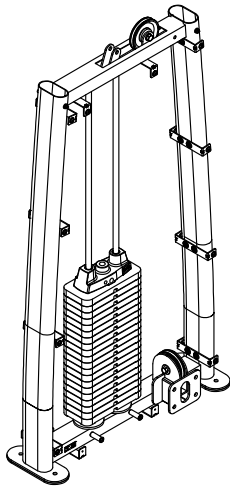

Above shows STEP 8  
assembled and completed

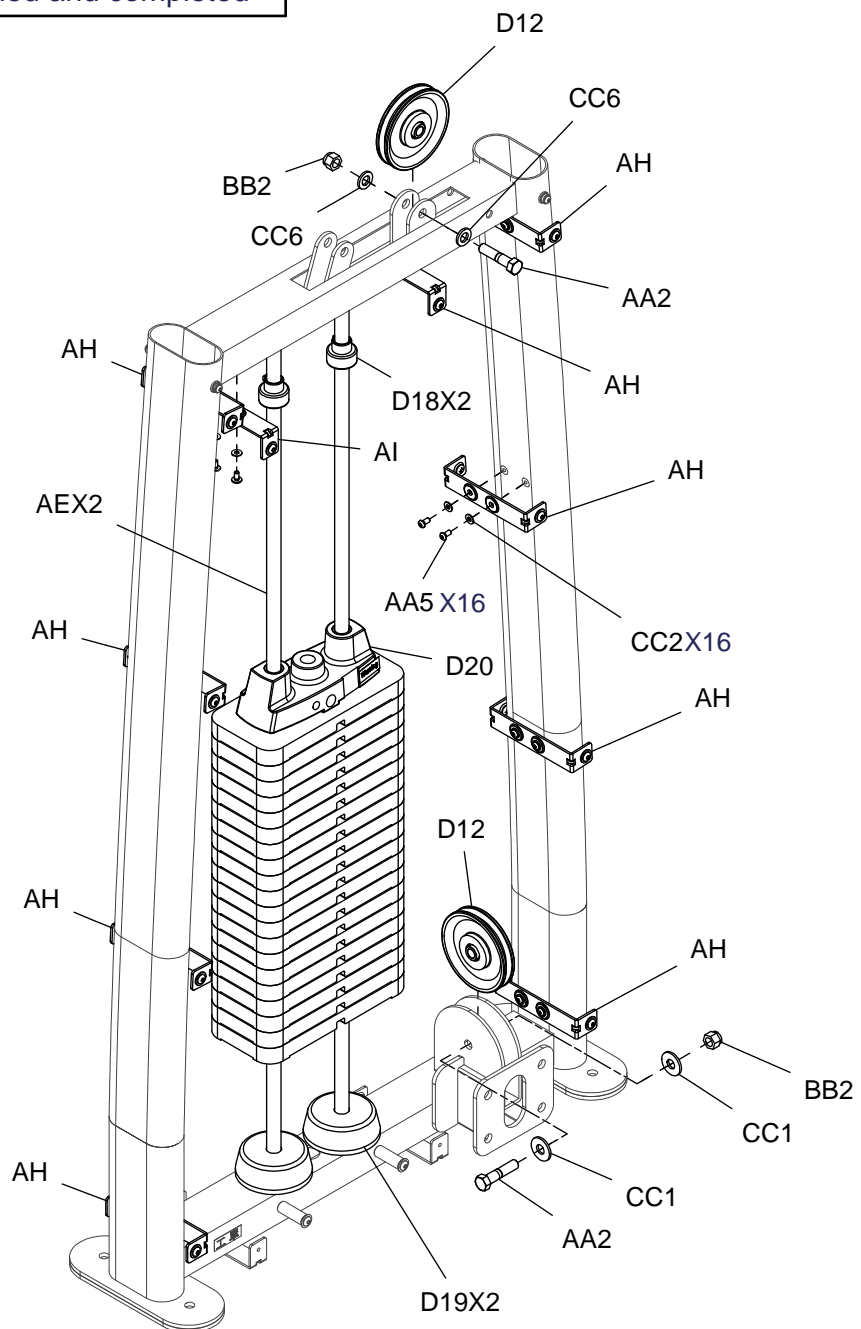

# DLEC ASSEMBLY INSTRUCTIONS

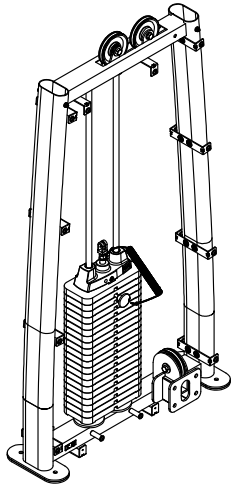

Above shows STEP 9  
assembled and completed

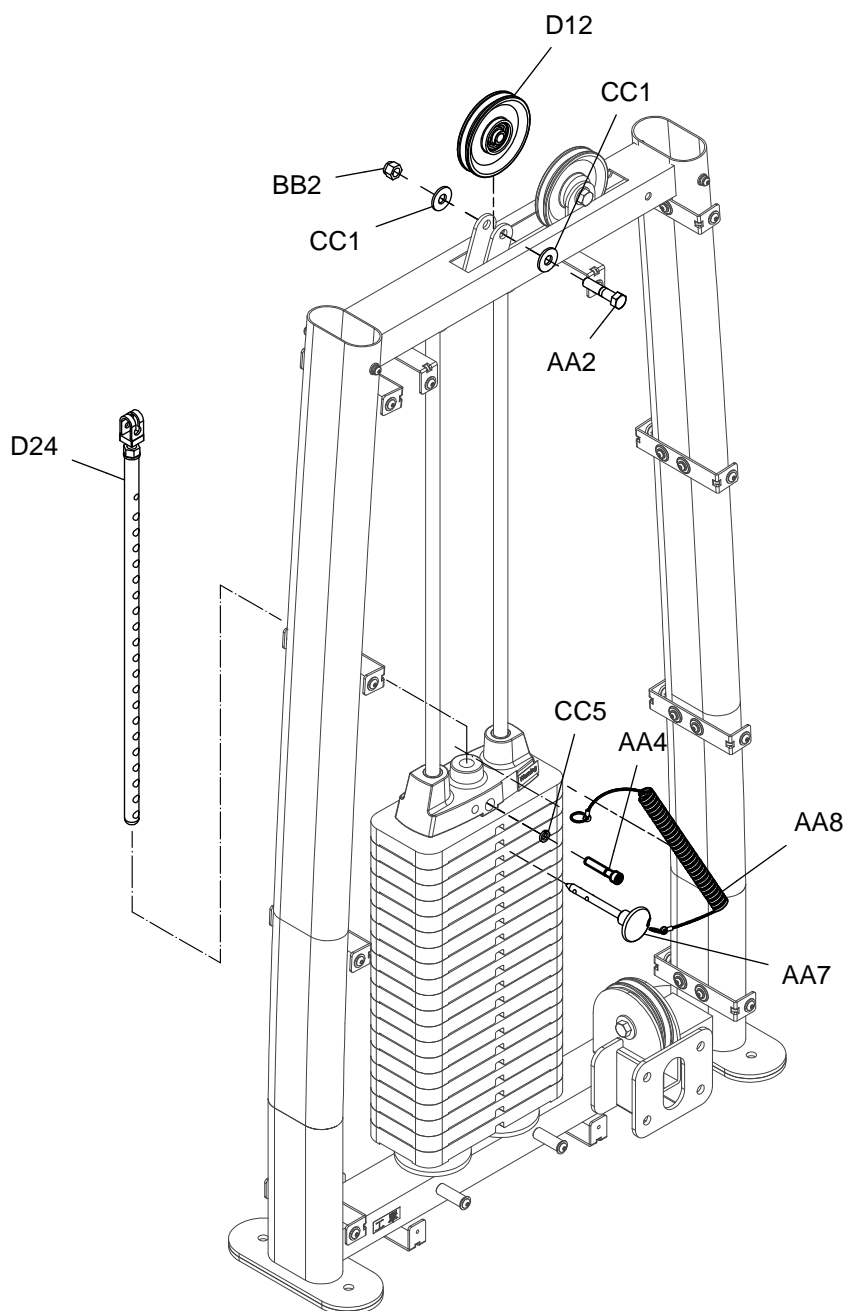

# DLEC ASSEMBLY INSTRUCTIONS

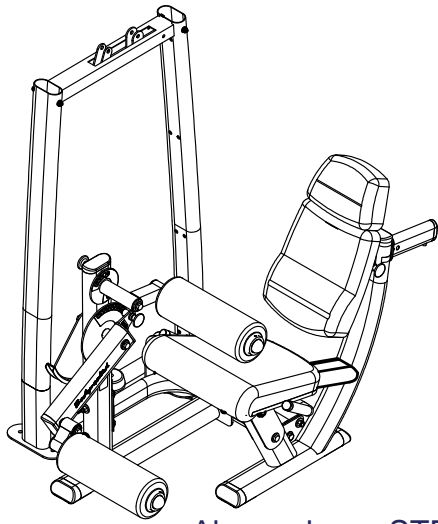

Above shows STEP 10  
assembled and completed

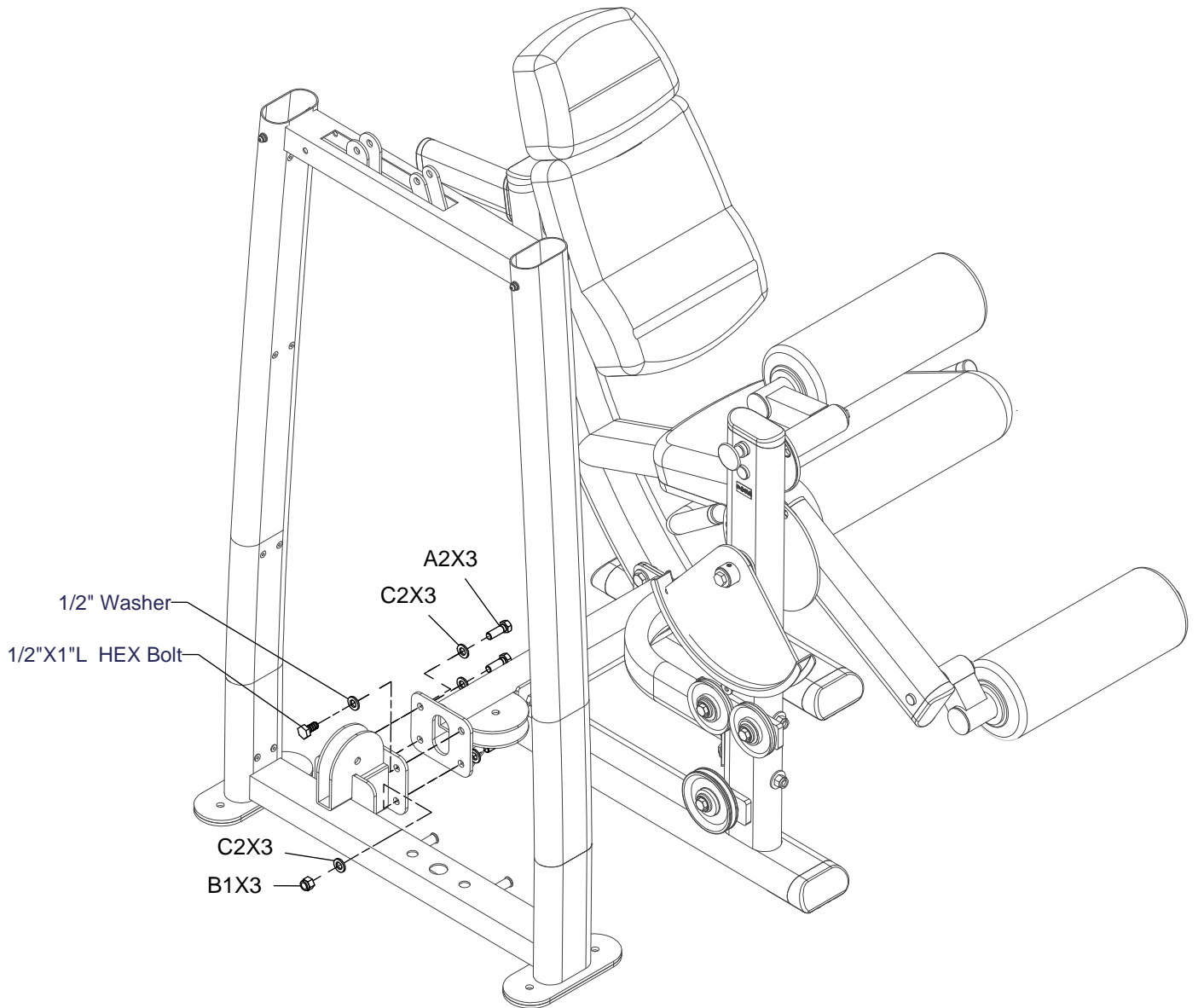

# DLEC ASSEMBLY INSTRUCTIONS

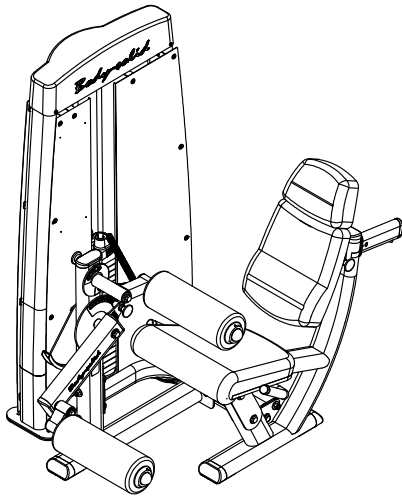

Above shows STEP 11 assembled and completed

D17.



### Detail View

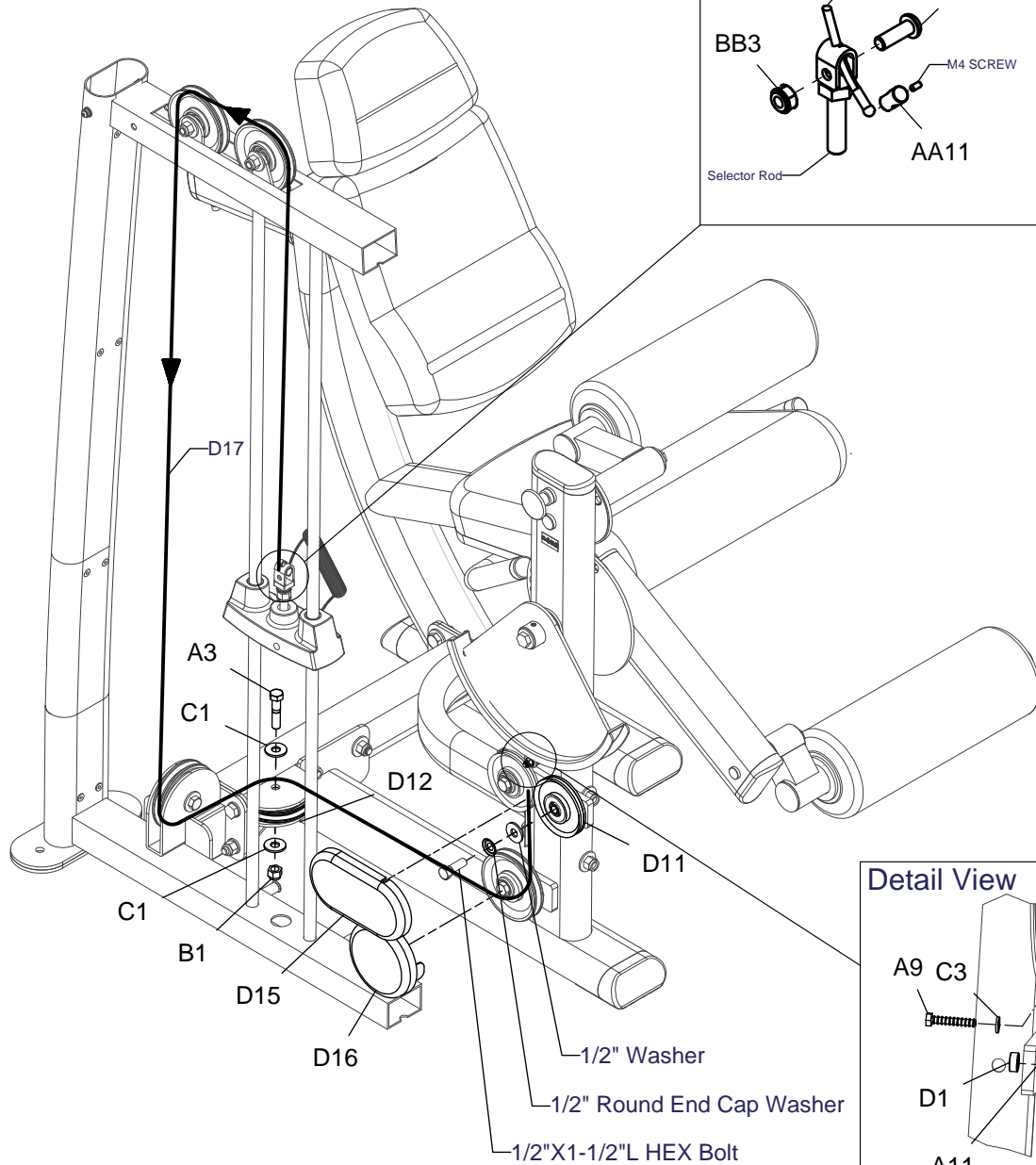
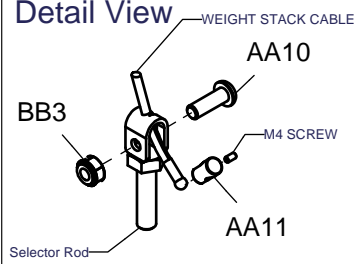

### Detail View

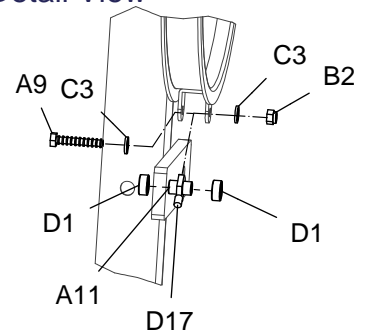

# DLEC ASSEMBLY INSTRUCTIONS

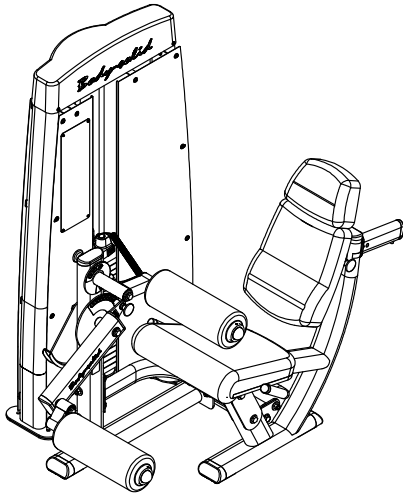

Above shows STEP 12 assembled and completed

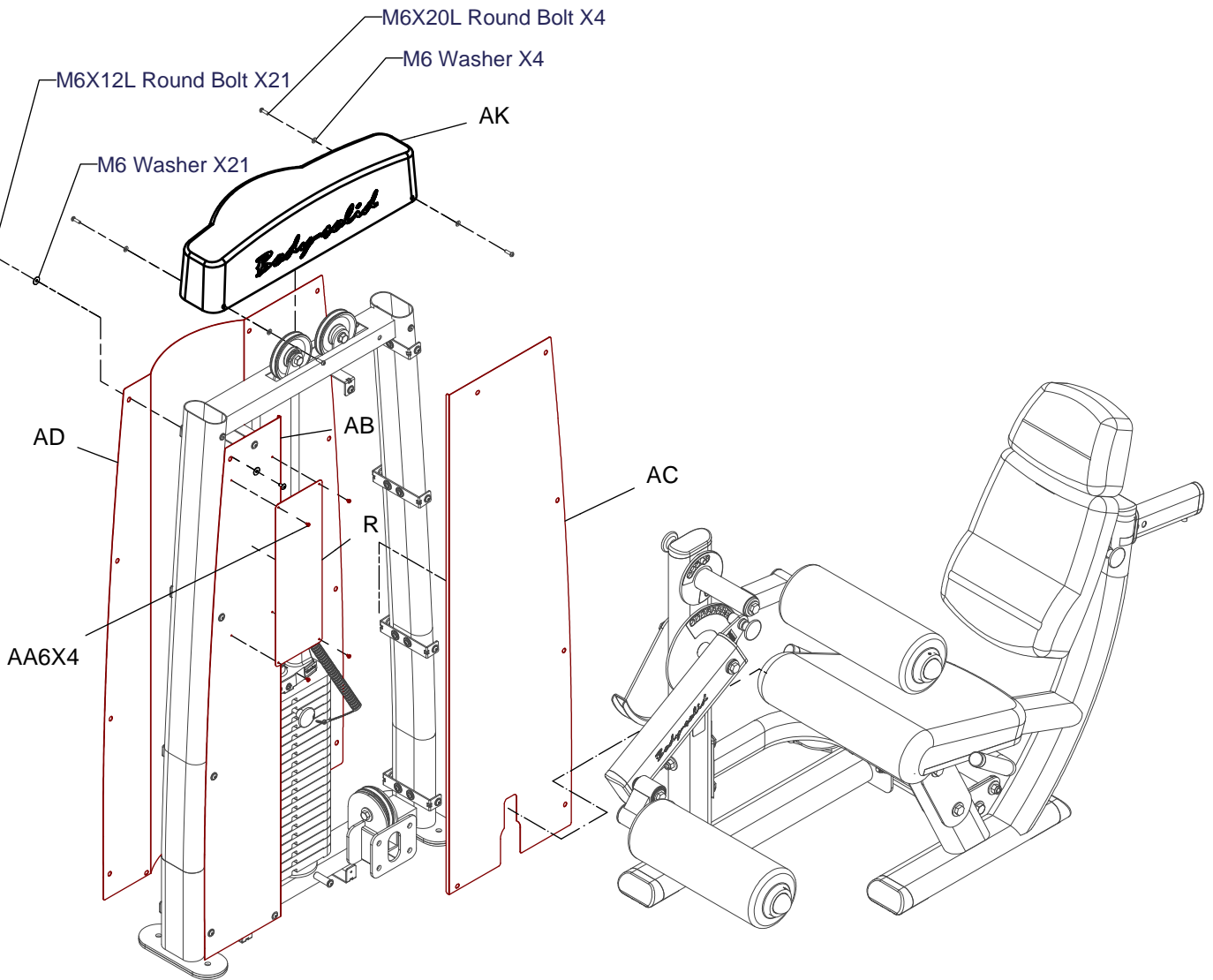

# DLEC ASSEMBLY INSTRUCTIONS

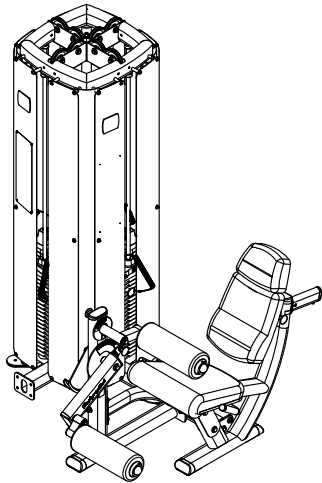

Above shows STEP 13 assembled and completed

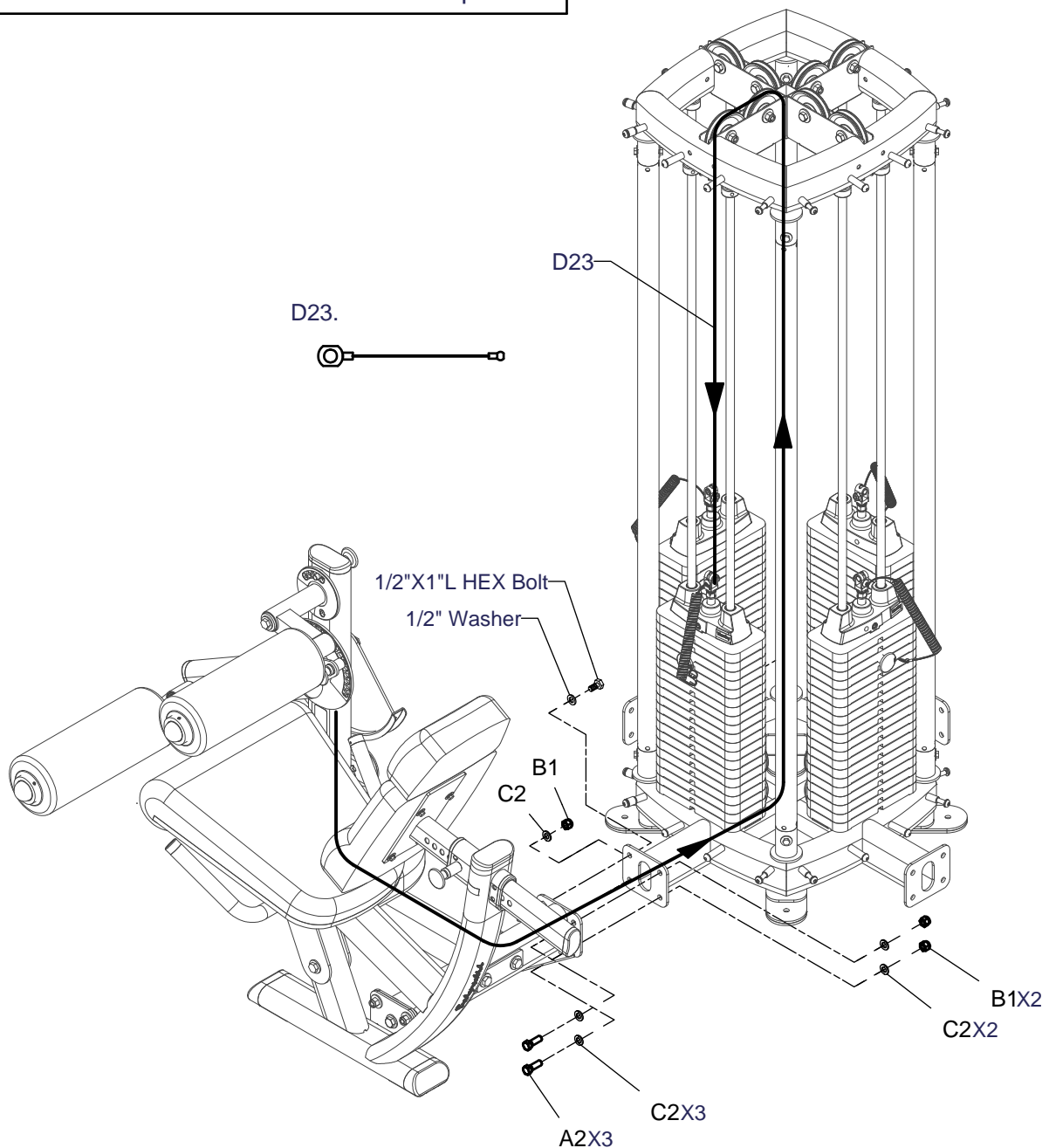

# DLEC ASSEMBLY INSTRUCTIONS

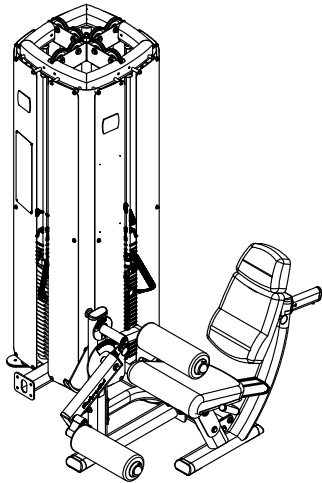

Above shows STEP 13  
assembled and completed

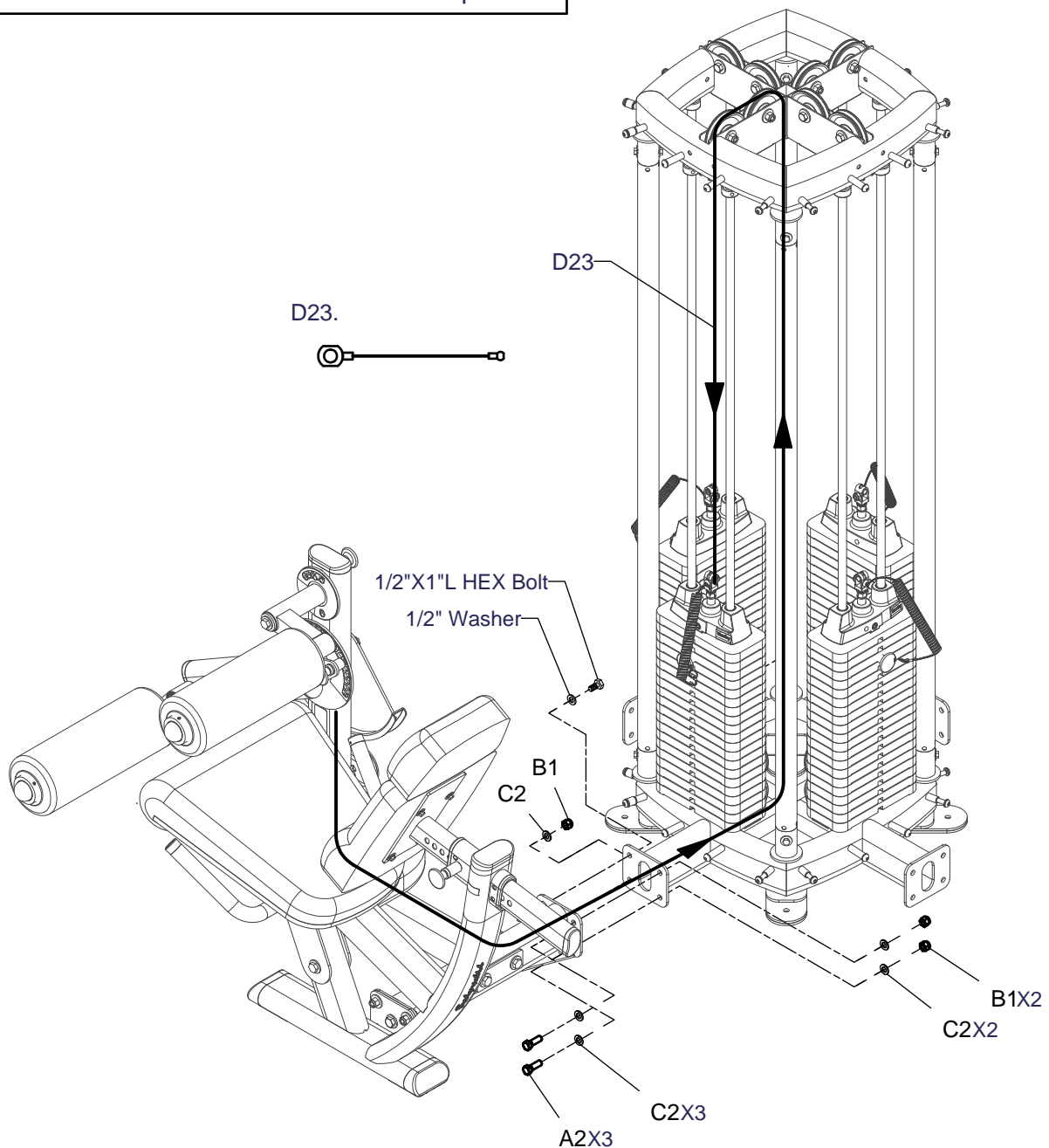



# DLEC ASSEMBLY INSTRUCTIONS

